



1201/1202 Series
KSI VIBRAPLANE
VIBRATION ISOLATION
WORKSTATION

ASSEMBLY AND OPERATION
INSTRUCTIONS MANUAL

Information contained in this document is subject to change without notice and does not represent a commitment on the part of Kinetic Systems, Inc. Revisions D on March, 2008 to this document, or new editions of it, may be issued to incorporate such changes.

CONTENTS

Section I.	Page
As You Begin.....	1
• Technical Assistance	
• Damage Due To Shipping	
 Section II.	
Set Up Procedure.....	2-10
• Isolation Leg Stand	
• Optional Fixed Shelf	
• Optional Sliding Shelf	
• Optional Monitor Support	
• Optional LCD Monitor Support	
• Optional Padded Arm Rest	
• Optional Rear and Side Equipment Shelf Assembly	
• Optional Casters	
 Section III.	
Operation.....	10-12
 Section IV.	
Trouble Shooting.....	13&14
• Symptom: Tabletop Will Not “Float.”	
• Symptom: Tabletop “Floats” But Will Not Isolate.	
• Symptom: Tabletop Over-Reactive	
 Section V.	
Recommended Spare Parts.....	14
 Section VI.	
Replacement Boot Installation.....	15&16
 Section VII.	
Filter Regulator Installation and Operation.....	17&18
 APPENDIX	
• VIBRAPLANE Model 1201/1202 Table Warranty.....	19

List of Illustrations.

Fig. 1 Outline Drawing of 1201/1202 Table.....	2
Fig. 2 Leg Height Adjustment.....	3
Fig. 3 Installation of Constraints (1202 only) or optional Guardrail(s).....	4
Fig. 4 Optional Fixed Shelf Assembly.....	5
Fig. 5 Optional Sliding Shelf.....	5
Fig. 6 Monitor Support Assembly.....	6
Fig. 7 Optional Padded Arm Rest.....	7
Fig. 8 Optional Rear or Side Equipment Shelf Assembly.....	8
Fig. 9 Installation and Use of optional Caster.....	9
Fig. 10 1201/1202 Airline Schematic.....	10
Fig. 11 Valve Adjustment Illustration.....	11
Fig. 12a 1201 Replacement Boot Installation.....	15
Fig. 12b 1202 Replacement Boot Installation.....	15
Fig. 13 Filter Regulator Installation and Operation.....	17

Section I

As You Begin:

Congratulations! The VIBRAPLANE Model 1201/1202 Vibration Isolation Table you have purchased has been designed by Kinetic Systems, Inc. for many years of trouble-free user service. It will deliver superior vibration isolation performance for a broad range of research, quality assurance, and production application.

The VIBRAPLANE Model 1201/1202 Vibration Isolation System is a four leg Active Air Suspension System. The maximum gross load capacity for the VIBRAPLANE Model 1201 and 1202 are 1300 lbs, and 2800 at 80 PSI respectively. If the VIBRAPLANE 1201/1202 Table is to be operated at less than maximum gross load capacity, a proportionately lower pressure air source may be used. For example, a 30 to 50 PSI air source is generally adequate for most small instruments.

In order to get full benefit from your VIBRAPLANE Model 1201/1202 Table, we suggest you follow the easy, step-by-step instructions in this manual.

Technical Assistance:

Need Technical Assistance? First, refer to the “Troubleshooting” Section of this Manual. If your problem persists, the technical support staff at Kinetic Systems, Inc. will be glad to answer any questions. Just call us at (617) 522-8700, or FAX (617) 522-6323 or email sales@kineticsystems.com.

Damage due to shipping:

When your VIBRAPLANE 1201/1202 Table Arrives, inspect it carefully for any damage due to shipping. If ANY DAMAGE IS DETECTED, NOTIFY THE SHIPPING CARRIER IMMEDIATELY. SAVE ALL PACKING MATERIALS.

Section II

Set Up Procedure:

The following equipment and tools are recommended to set up your 1201/1202 Vibration Isolation Table.

- A hydraulic lifting device
- A carpenter's level
- A screwdriver
- An adjustable wrench

Refer to Fig. 1 and 2 for an outline view of your VIBRAPLANE Model 1201/1202 including optional accessories you may have ordered, such as Guardrails, Kinematic Horizontal Isolation Feet, Sliding Shelf, or Fixed Shelf.

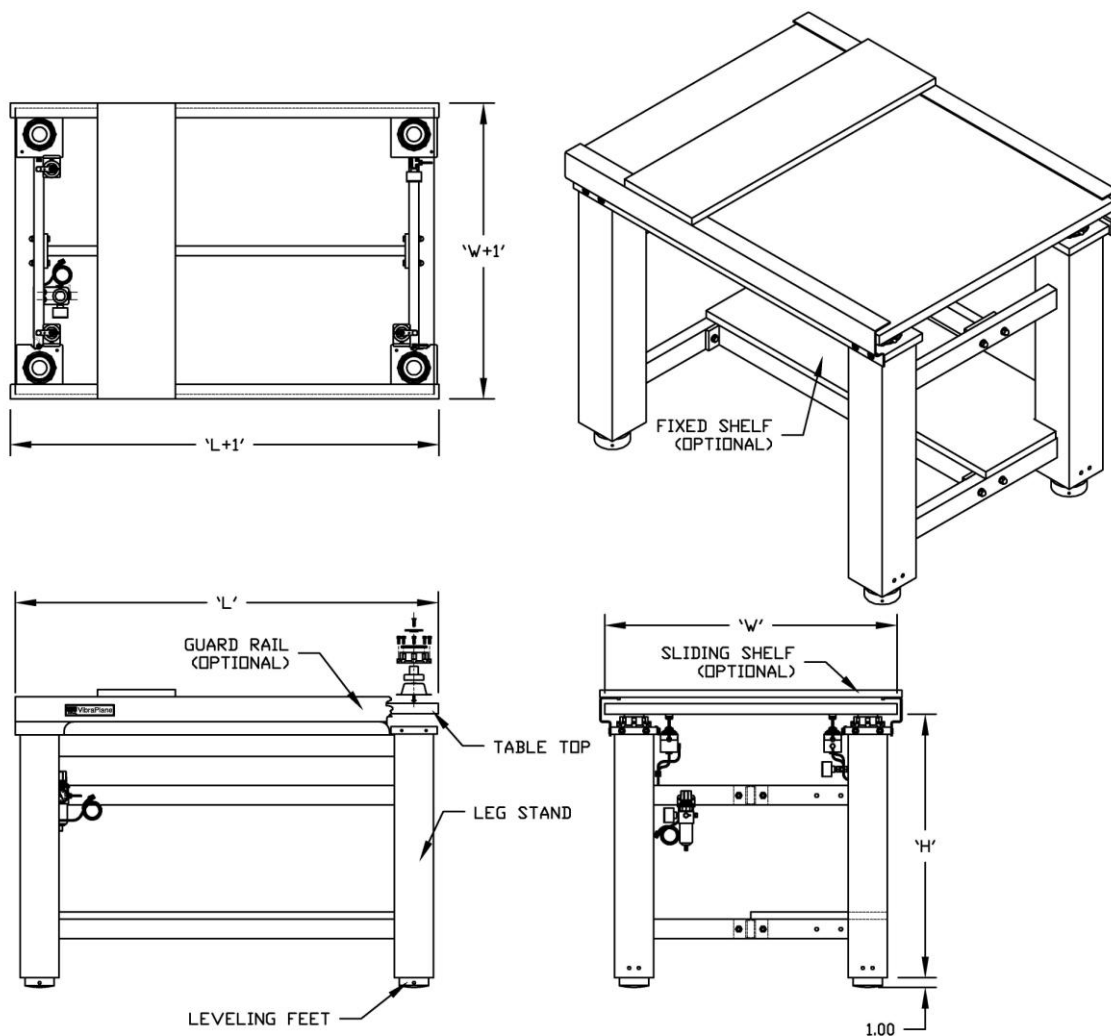

Fig. 1 1201/1202 Vibration Isolation Table

Isolation Leg Stand:

1. Carefully remove all shipping materials (metal strapping, cardboard, etc.). Additional parts such as four (4) Constraints (1202 only), optional Guardrails, or optional Kinematic Horizontal Isolation Feet have been packed separately inside the shipping container. Set these parts aside for later installation.
2. Remove the protective wood blocks from the bottom of each leg. The four (4) mechanical Leveling Feet are fully retracted for shipping. Rotate each foot **CLOCKWISE** (see Fig. 2) so that it extends $\frac{3}{4}$ " below the bottom of the leg.

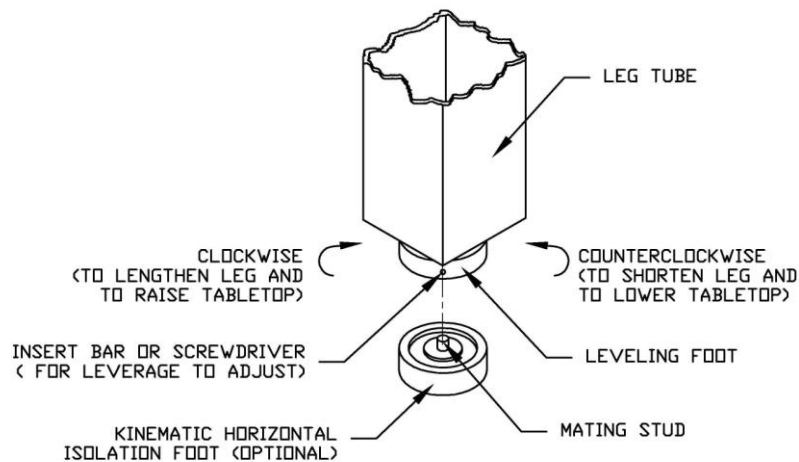

Fig. 2 Leg Height Adjustment

3. Move the four-leg assembly to its final installation location. If the back of the table is to be positioned against the wall, be sure to leave enough access space to permit attachment of the rear constraint or optional Guardrail(s).
4. If you have ordered the optional Kinematic Horizontal Isolation Feet, these should be unpacked and installed now (as shown in Fig. 2). Raise each leg one at a time and insert the projecting stud of the Kinematic foot into the mating hole at the bottom of the Mechanical Leveling Foot. Be sure the Kinematic Foot and the Mechanical Leveling Foot are in perfect alignment.
5. Remove the yellow plastic caps (1202 only), which cover the top of the legs. These plastic caps are used only for protection of the leg assembly during shipping, and they may be discarded.
6. The Tabletop weighs several hundred pounds, so use of a hydraulic lifting device is recommended for its installation. Lower the Tabletop to $\frac{1}{2}$ " above the leg assembly. Center the Tabletop left-to-right and front-to-back. Proper positioning of the Tabletop is important for even distribution of weight on the legs and to avoid rubbing against the Constraints or optional Guardrails. When the Tabletop is positioned properly above the legs, lower it gently onto the leg assembly.

7. Unwrap the four (4) Constraints (1202 only) or optional Guardrail(s). Hold the Constraints or Guardrails in place, and check for adequate clearance along the edges of the Tabletop. Reposition the Tabletop if necessary.
8. Remove the eight (8) 1/4-20 Flat Head Screws and Finish Washers screwed in at the top of each leg (2 per leg). Remove the white protective paper from the VISCODAMP material laminated on the four (4) Constraints or optional Guardrail(s), and bolt them securely in place as shown in Fig. 3, using the Screws and Finish Washers removed from the legs.

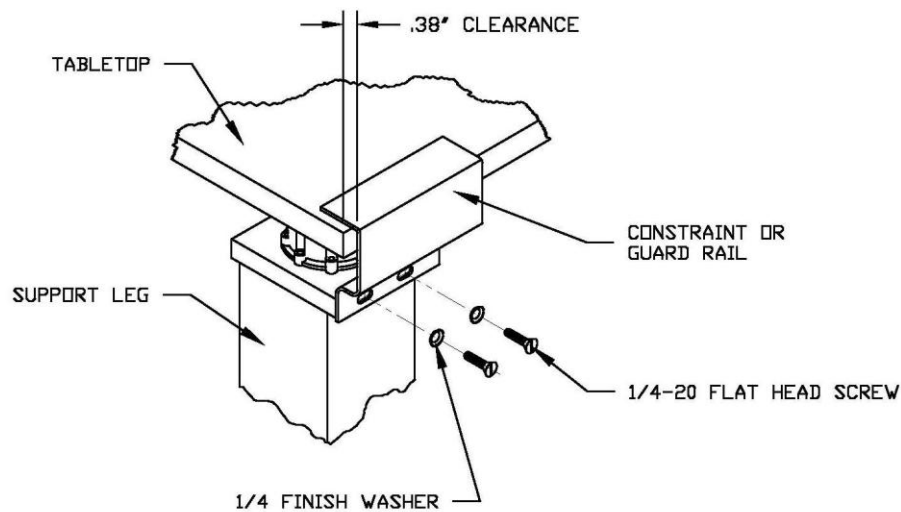

Fig. 3 Installation of Constraint (1202 only) or Optional Guardrail(s).

9. Place a carpenter's level diagonally across the Tabletop and check for level condition (both direction).
10. If an out-of-level condition is detected, adjust the Leveling Foot by inserting a thin rod or screwdriver (as shown in Fig. 2) into the hole on the side of the Leveling Foot. Rotate COUNTERCLOCKWISE to shorten leg and lower the Tabletop. Rotate CLOCKWISE to lengthen leg and raise Tabletop. After you have leveled the Tabletop all 4 legs should be in contact with the bottom surface of the Tabletop, if any gap is observed rotate the leveling foot clockwise to close the gap.
11. If you installed optional Kinematic Horizontal Isolation Feet, ensure that each foot is still aligned concentrically with the Mechanical Leveling Foot. If necessary, realign by tapping the side of the Kinematic foot with the handle of a screwdriver or a small hammer.
12. Your VIBRAPLANE Model 21201/1202 Vibration Isolation Table is now ready for operation.

Optional Fixed Shelf:

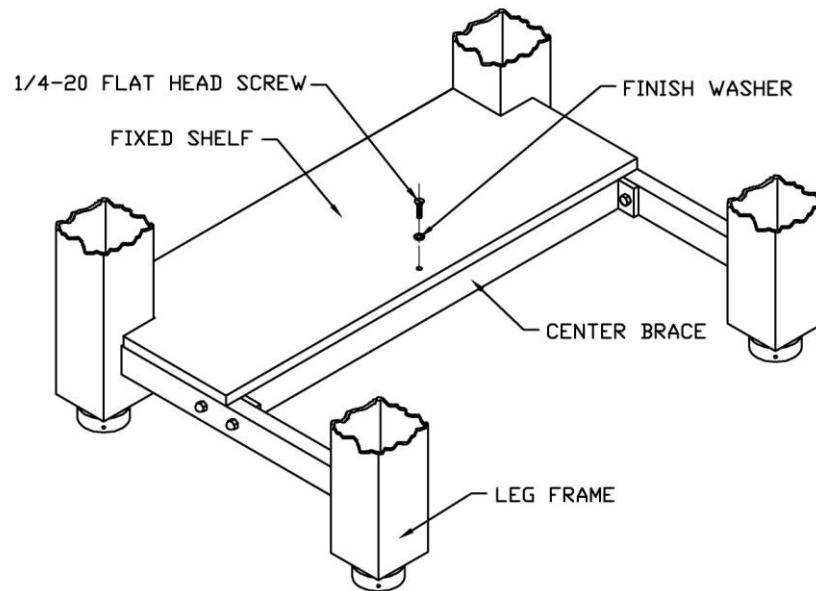

Fig. 4 Optional Fixed Shelf Assembly.

1. Unpack and locate the Fixed Shelf on the bottom Leg Stand brace (Refer to Fig. 4).
2. Position the clearance hole on Fixed Shelf over the tapped hole in Center Brace of the Leg Stand.
3. Bolt Fixed Shelf in place using 1/4-20 flat head screw and Finish Washer provided.

Optional Sliding Shelf:

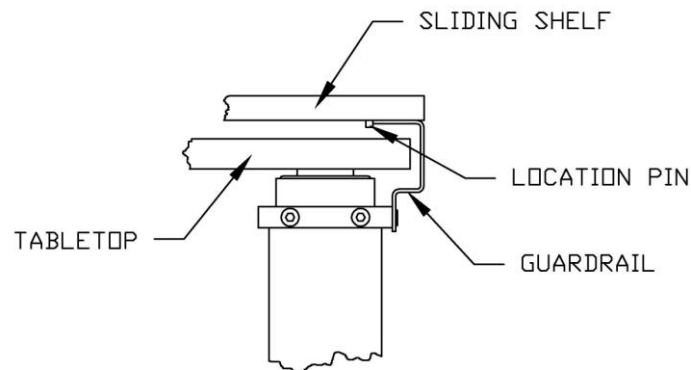

Fig. 5 Optional Sliding Shelf.

1. Place the Sliding Shelf on the top of the System Guardrails. Locator pins on each end of the shelf will provide positive alignment of the shelf from front to back (refer Fig. 5).
2. The Shelf or Shelves can slide from left to right to any position desired.

Optional Monitor Support:

The following instructions explain how to install the optional Monitor Support assembly (Refer to Fig. 6).

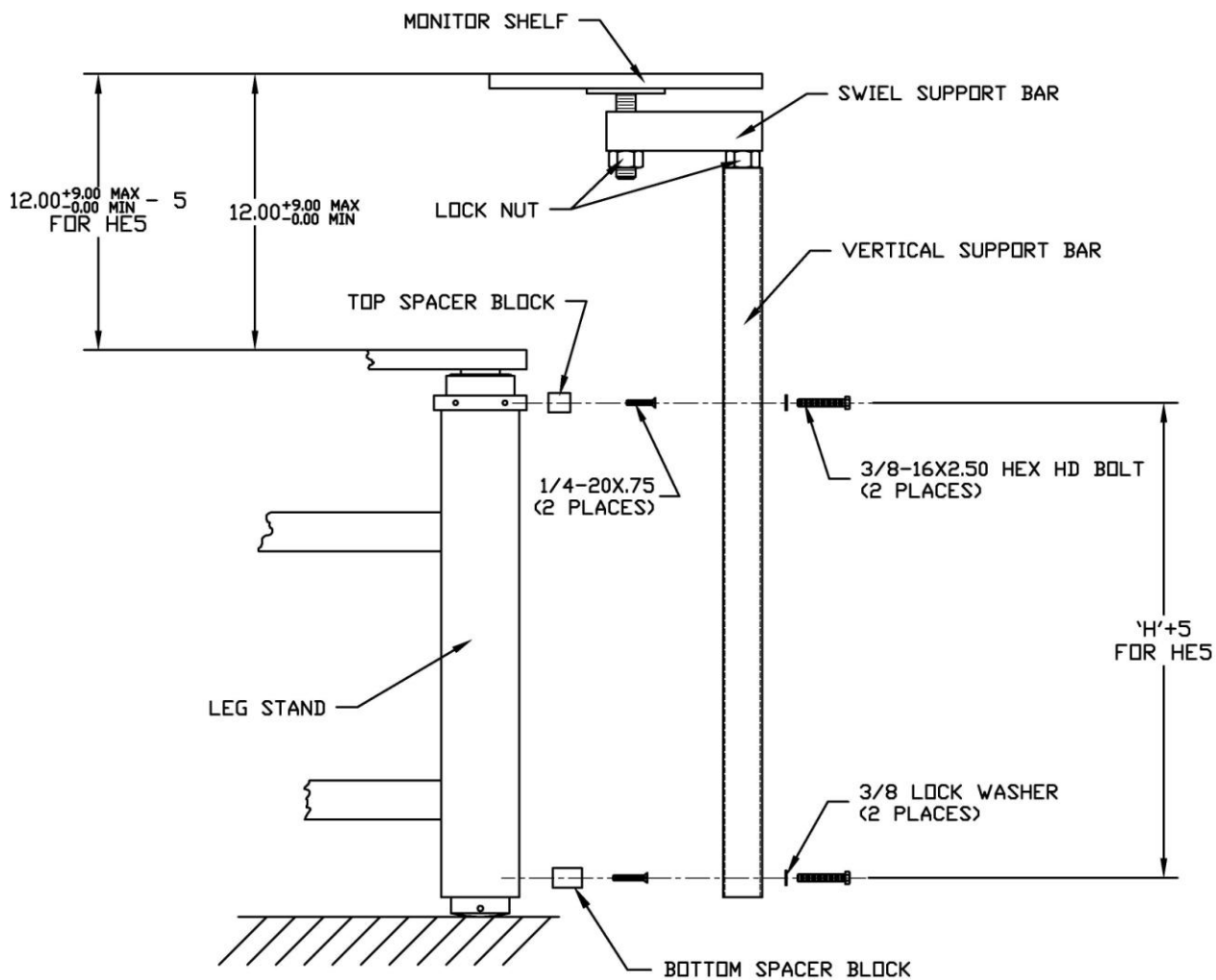

Fig. 6 Optional Monitor Support.

1. Be sure your VIBRAPLANE Model 1201/1202 Table is SET UP as described in the previous section of this manual.
2. The Monitor Support is shipped in three sub assemblies: The Monitor Shelf Assembly, the Swivel Support bar Assembly, and the Vertical Support Bar Assembly.
3. Install Top and Bottom Spacer Blocks in place by lining up the two holes of the two spacer blocks with the 1/4-20 UNC holes on the leg stand (on the side) and secure in place using two 1/4-20X0.75" long flat head screws for Top Spacer Block and two 1/4-20x1.75" flat head screws for Bottom Spacer Block.

4. Hold the Vertical Support Bar firmly in place, lining up the lower hole with the hole in the bottom spacer block and upper hole with the top spacer block. Bolt the Vertical Support Bar in place using the two 3/8 spring lock washers and two 3/8-16X2.50" hex head bolts provided.
5. Position the Swivel Support Bar on top of the Vertical Support Bar, and screw in clockwise until the desired height is reached.
6. Screw the Monitor Shelf Assembly into the threaded portion of the Swivel Support bar Assembly.
7. Tighten both lock nuts to prevent unwanted movement.
8. Further adjustments of the Monitor Shelf can be made by rotating the Swivel Support bar Assembly or the Monitor Support Assembly.

Optional LCD Monitor Support Assembly:

The LCD monitor support assembly is shipped in two parts, the LCD monitor support and the Support Post assembly. Refer to steps 3 & 4 of previous section '*Optional Monitor Support Assembly*' to secure the support post to your 1200 table. Refer to figure 6a for securing the optional LCD monitor support to your support post.

1. Attach the LCD monitor support back plate to the monitor support post using four 1/4-20 X 0.5 long hex head screws with washers. If the mounting plate is not attached to the post already, use four 10-32 screws (provided) to secure it to the post.
2. Attach the LCD monitor support to the back plate using the four M6X12mm screws as shown in the figure.

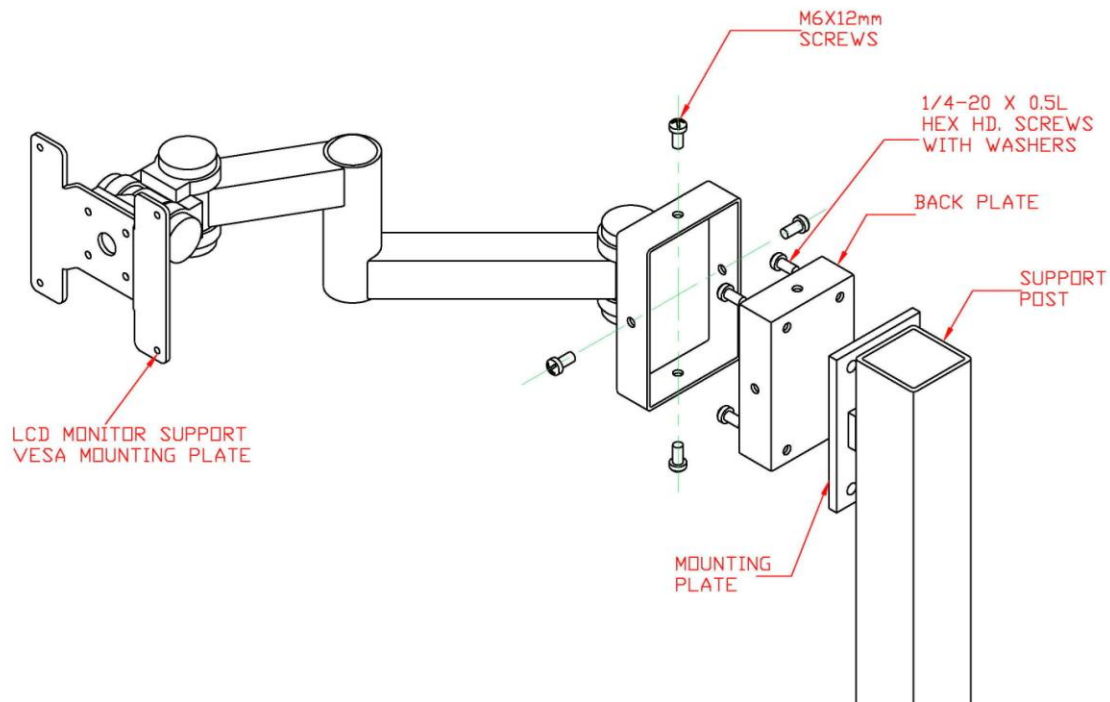

Figure 6a. Optional LCD Monitor Support Assembly

Optional Padded Armrest:

1. The optional adjustable padded Armrest is ordered in pairs. (Refer Fig. 7).

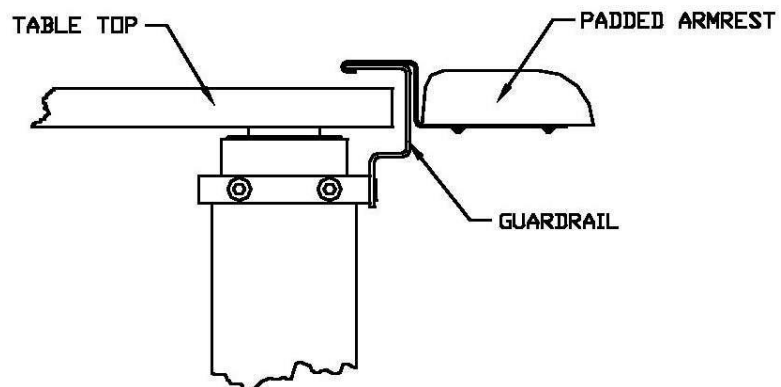

Fig. 7 Optional Padded Armrest.

2. To install the adjustable padded armrests simply drop onto the guardrail (as shown Fig. 7). They can then be slid into any position desired.

Optional Rear and Side Equipment Shelf Assembly:

The following instructions explain how to install the Optional Rear and Side Equipment Shelf Assembly (Refer to Fig. 8).

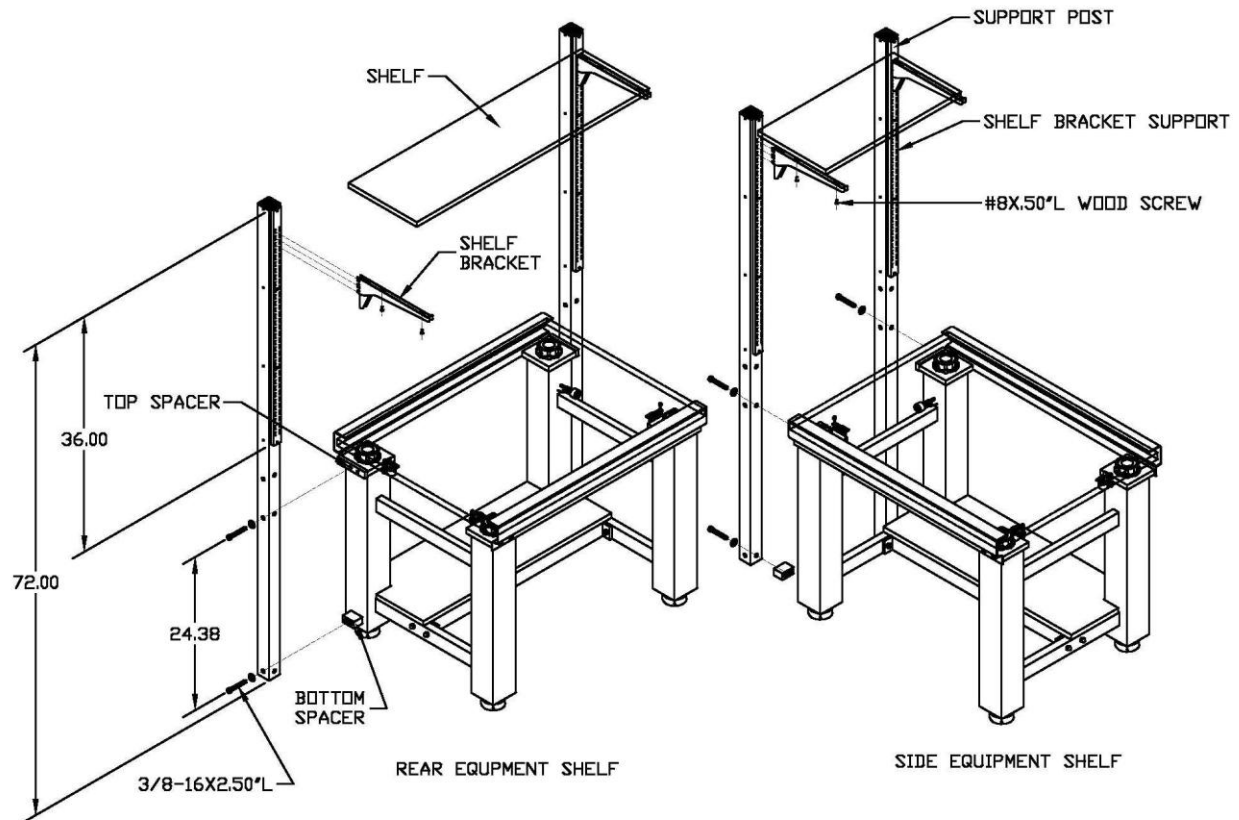

Fig. 8 Optional Rear and Side Equipment Shelf Assembly.

1. Be sure your VIBRAPLANE Model 1201/1202 Table is SET UP as described in the previous sections of this Manual.
2. Unpack the Support Posts, Shelf brackets, and the Shelf.
3. Attach the Support Posts to the Top and Bottom Spacers using the 3/8-16UNCx2.5" long hex head bolts. (See *Optional Monitor Support* section on page 7 for instructions on installing the spacers).
4. Position the Shelf Brackets in the slots on the Shelf Bracket Support to achieve the desired height for the Shelf.
5. Place and center the shelf on the Shelf Brackets.

- Secure the Shelf into place by screwing the #8x.50" long wood screws into the bottom of the shelf from the underside of the Shelf Bracket.

Optional Casters:

- The optional Casters supplied with the 1201/1202 Vibration Isolation Table are retrofittable, which means that they could be added to 1201/1202 Vibration Isolation Tables already in the field.
- In order to set up the Casters first retract the Casters to their lowest possible positions.
- Adjust the Mechanical Leveling Feet on the Table so that they extend down from the Leg Tube by approximately 1 inch (Refer to Fig. 9).
- You are now ready to attach the Caster to the Leg Tube. The Caster can be attached to either of 2 sides on the Leg Tube.
- Place the Caster Assembly onto the Leg Tube on the side best suited and slide the Caster Assembly up, making sure the hook assemblies on the back of the Caster Assembly are on the inside of the Leg Tube.
- Tighten the 2 nylon tipped Set Screws on each Caster Assembly. These will hold the Caster Assemblies in place when they are not in use.

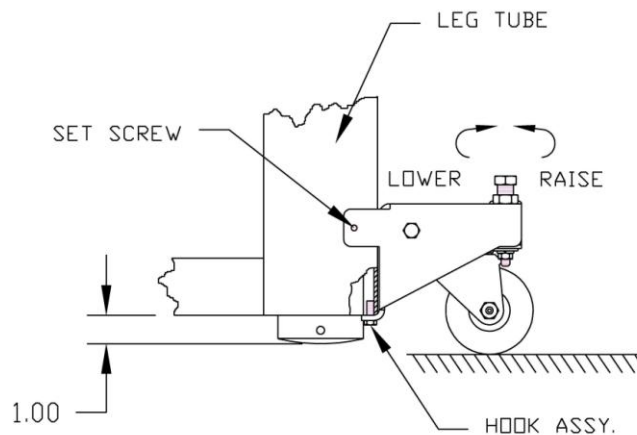

Fig. 9 Installation and use of Optional Caster.

- To remove the Caster Assembly reverse the previous procedure.
- Engaging the Caster can be done by turning the bolt on top of the Caster Assembly clockwise until the Caster plate is horizontal or parallel with the floor. The leveling Foot on that leg should rise, if more clearance is needed this can be done by raising the Leveling Foot into the Leg Tube.

9. Lower all four Casters and the System is ready to be moved. It is recommended to have at least $\frac{1}{4}$ " clearance between the Leveling Foot and the floor.
10. Once the System is in its desired location, raise the Casters by reversing the previous steps and relevel the System. It is not recommended to float the system while the casters are engaged and supporting the table.

Section III

Operation:

The model 1201/1202 is delivered pretested and ready for operation when connected to the user's pressurized air supply.

1. Using the Umbilical Assembly (1/4"ODX15 ft. polyethylene tubing and 1/4" NPT fitting), connect the pressurized air supply to the inlet of the Filter Regulator (as shown in Fig. 10). The Polyethylene tubing may be shortened by cutting with a tubing cutter. If additional pipe fittings are required to complete the connection at the pressurized air supply, they must be supplied by the user.

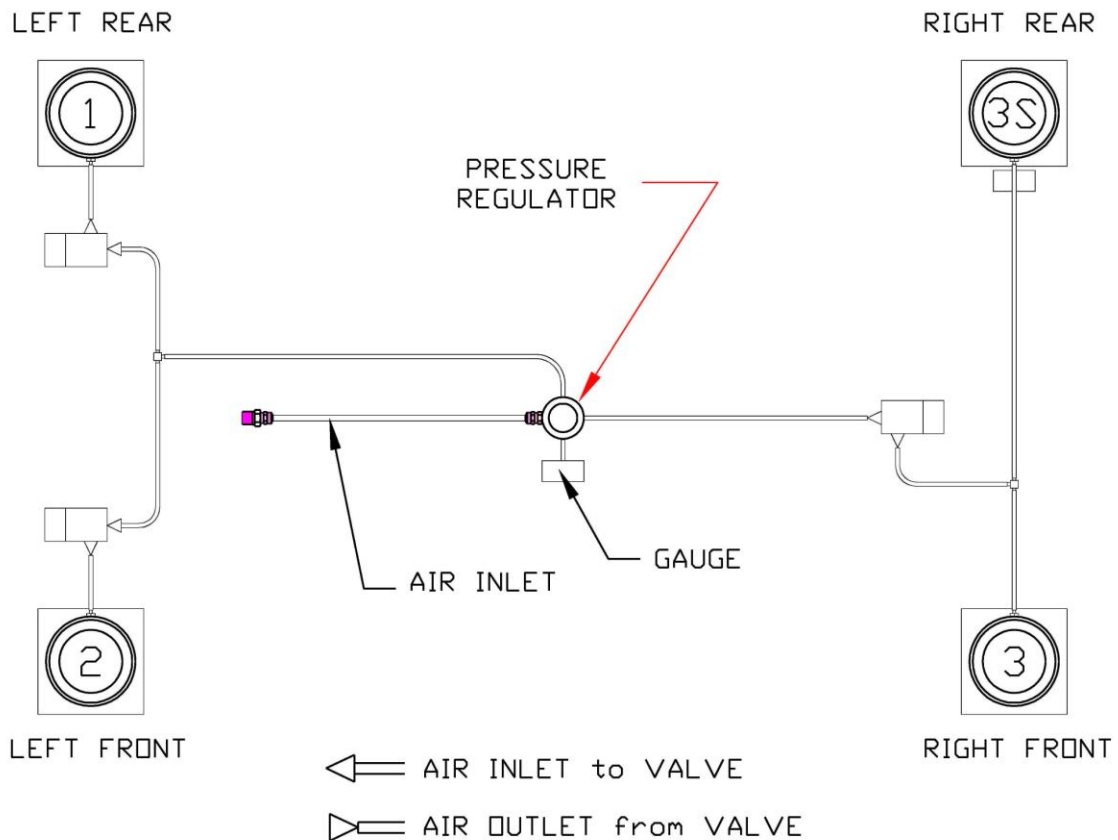

Fig. 10 1201/1202 Airline Schematic.

2. The pressurized air supply should be clean dry air or nitrogen from a regulated line or bottle, with pressure not to exceed 100 PSI.
3. Position your equipment on the Tabletop, centering it as much as possible.
4. Turn on the pressurized air supply and adjust the Filter Regulator until the gage reads approximately 80 PSI.
5. Be sure the Valve Adjustment Screw on each VIBRA-LEVEL Valve Arm is touching the bottom surface of the Tabletop, and that each Valve Arm is slightly below horizontal for the fill position and about 10 degree above horizontal for neutral position.
6. The Tabletop should begin to “float” within 5 to 10 minutes. If floating does not occur at one or more legs, check the inlet pressure on Filter Regulator and raise the supply pressure if necessary or turn the Valve Adjustment Screw(s) COUNTERCLOCKWISE.
7. When the Tabletop is completely “floating” adjust each Valve Adjustment Screw so that the Tabletop is floating approximately $\frac{1}{4}$ of an inch (as shown in Fig. 11). The Tabletop should be level at this point since leveling was done prior to this by raising and lowering of the Mechanical leveling Feet.

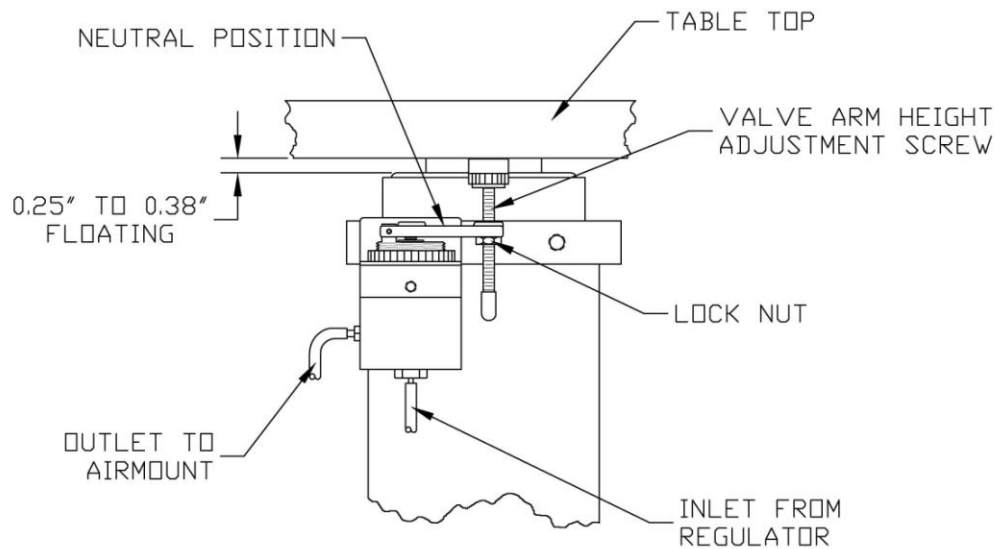

Fig. 11 Valve Adjustment Illustration.

8. Tighten the Lock Nut on each of the Valve Adjustment Screws.
9. Once the tabletop with your equipment is “floating”, read the system Pressure Gage on the right rear (slave) leg, and adjust the Filter Regulator Gage to read approximately

10-15 PSI higher than the system Pressure Gage. For example: If the system Pressure Gage reads 55 PSI, adjust the Filter Regulator Gage to read 65 to 70 PSI.

10. If more equipment load is added to the Tabletop, you may increase the air pressure at the Filter Regulator Gage to accommodate it. It is recommended not to exceed 80 PSI Filter Regulator pressure.
11. Once the VIBRAPLANE Model 1201/1202 has been adjusted, it will maintain its level automatically as long as the system remains pressurized. If the air pressure is shut off for an extended period of time and then repressurized, the Model 1201/1202 Tabletop will automatically return to its preset height.

CAUTION: Never remove heavy loads from the Tabletop suddenly. Two options are recommended for removal of heavy loads: (1) remove heavy loads gradually to permit controlled pressure reduction in the legs by the VIBRA-LEVEL Servo Valves or (2) reduce the pressure in the Filter Regulator gage to below what is required to support the Tabletop.

Section IV

Trouble Shooting:

The purpose of this section is to aid the user in the diagnosis and repair of any minor problems that may occur. If your difficulty persists, call Kinetic Systems, Inc.'s technical support staff for assistance.

Symptom: Tabletop Will Not "Float"	
Possible Cause	Probable Solution
Valve Arms set incorrectly	Adjust Valve Arm
Supported load too heavy	Reduce load to system capacity
Supported load uneven	Redistribute load evenly
Gross air leak	Locate leak and repair
Air restriction in fitting or tubing	Find restricted fitting or Tube and replace

SYMPTOM: TABLETOP "FLOATS" BUT WILL NOT ISOLATE	
Possible Causes	Probable Solutions
Rubbing between Tabletop and system structure.	Reposition Tabletop.
Foreign object between Tabletop and system structure.	Remove foreign object.
Wires or tubing too stiff.	Use more flexible wire or large service loop.
One piston too high.	Lower the piston by turning the Valve Arm Adjustment Screw CLOCKWISE .
One piston too low.	Raise the piston by turning the Valve Arm Adjustment Screw COUNTERCLOCKWISE .

Symptom: Tabletop Over Reactive	
Possible Causes	Probable Solutions
Air Pressure differential too high (i.e., more than 10-15 PSI)	Reduce air pressure differential to 10-15 PSI.
Equipment on Tabletop has a high center of gravity.	Reduce air pressure differential to 5 PSI. IF Symptom persists, call Kinetic Systems, Inc.
VIBRA-LEVEL Servo Valve oscillating.	Call Kinetic Systems, Inc. for replacement.

Section V

RECOMMENDED SPARE PARTS:

While maintenance requirements for the VIBRAPLANE Model 1201/1202 Table are minimal, some parts can be damaged if the system is improperly moved. In order to avoid any inconvenience, Kinetic Systems, Inc. recommends that the user maintain a spare part inventory of possible replacement items. These items are listed below:

MODEL NO	QTY.	PART NO.	DESCRIPTION
1201	1	130200-05	Level Valve
1202	1	130200-05	Level Valve
1201	2	290300-01	Boot (320#) (Sales Order #)
1202	2	290300-13	Boot (700#) (Sales Order #)

Section VI

REPLACEMENT BOOT INSTALLATION:

The following instructions explain how to install a replacement boot for your VIBRAPLANE Model 1201/1202 Vibration Isolation Table (Refer to Fig. 12a & 12b).

Required Materials:

- Replacement boot (as per specification).
- Silicon Vacuum grease.

Required Tools:

- 5/32 Allen Wrench
- (1201) Philips Screw Driver (#2)

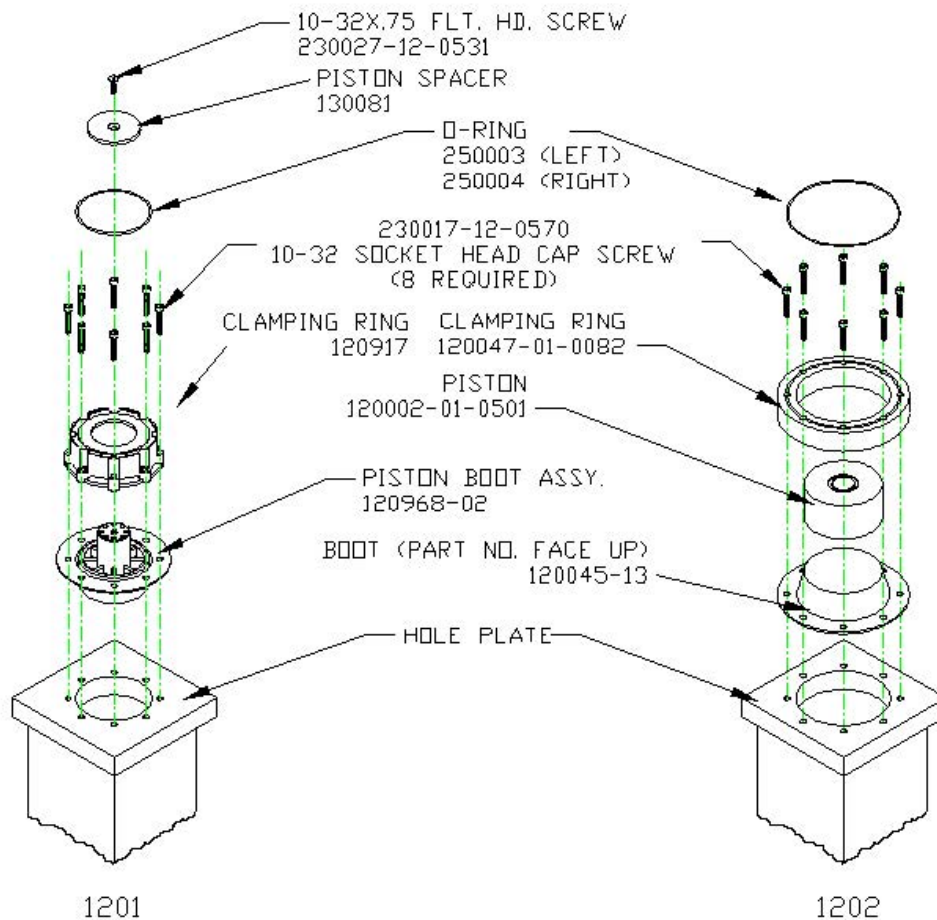

Fig. 12a 1201 Replacement Boot

Fig. 12b 1202 Replacement Boot

1. Turn off air supply and exhaust air from all Mounts by adjusting the valve arm screw to relieve the pressure. Make sure system legs are completely depressurized before removing the tabletop, especially for 1202 systems.
2. Remove damaged boot/piston-boot assembly step-by-step as shown on Fig. 12a and 12b. (As described in steps 3 - 5).
3. For 1202 models, peel back O-Ring (and remove if needed) from the top of Clamping Ring to access socket head screws and remove the piston from inside the leg. For 1201 models, while maintaining a grip on the piston shaft, unscrew fastener holding piston spacer in place.
4. Using a 5/32 Allen wrench, remove 10-32 socket head screws holding the Clamping Ring in place.
5. Remove Clamping Ring and damaged boot/piston-boot assembly.
6. Clean boot seat on the mount and apply a thin layer of vacuum grease (111 Molykote) to the mounting flange to ensure seal.
7. Place the new boot/piston-boot assembly on the mounting flange with “top hat” down for 1201 and “top hat” up for 1202 (as shown on Fig. 12a and 12b). Carefully match the boot hole pattern to the flange hole pattern.
8. Place the Clamping Ring over the piston and boot/piston-boot assembly matching up the hole pattern. (For 1202) The Counterbored holes should be up to provide a recess for the socket head mounting screws.
9. Carefully align and center the Clamping Ring, boot/piston-boot assembly, and flange holes.
10. Insert and hand tighten socket head screws, taking care to keep the boot/piston-boot assembly centered in the Clamping Ring. Tighten all screws, going in a diagonal pattern, until each screw is snug.
11. For 1202, if removed, replace the O-Ring (rubber bumper) into the groove on the Clamping Ring. If needed use adhesive to fix O-Ring back in place - DO NOT GET ADHESIVE ON THE BOOT.
12. For 1202, inspect the piston for burrs or debris. Clean if necessary. **For 1201**, grip piston shaft and replace piston spacer and screw - do not allow piston to spin around. One option is to inflate the leg with around 20 psi so that the piston is held in place without the need to grip piston shaft. To do this, set system regulator to 20 psi and press the leg's valve arm downward until the piston rises straight up. Be sure the piston-boot assembly is rising straight up - reference other leg's piston movement if needed.
13. For 1202 only, place the piston onto the boot so that the end with the larger radius corner is down against boot.
14. Replace the Tabletop and check for level condition.
15. The VIBRAPLANE Model 1201/1202 Table is now ready for operation.

Section VII

Filter Regulator Installation and Operation:

Installation

Install in vertical position so that air flow is in direction of arrow stamped on body of unit. Before piping-in, blow out the line to remove scale and other foreign matter. If pipe compound is used, apply only to male threads and just enough to make tight joints.

Reduced Pressure Adjustment

To unlock adjustment, pull knob out/up into forward most position. Turn knob clockwise to increase the reduced or regulated pressure and counter-clockwise to lower pressure. With relieving-type regulators, the reduced pressure follows adjustment of the screw, with non-relieving regulators adjustment for lower reduced pressure will not be obtained until the reduced pressure system is “bled-off” or until air flow starts (Refer to Fig. 13).

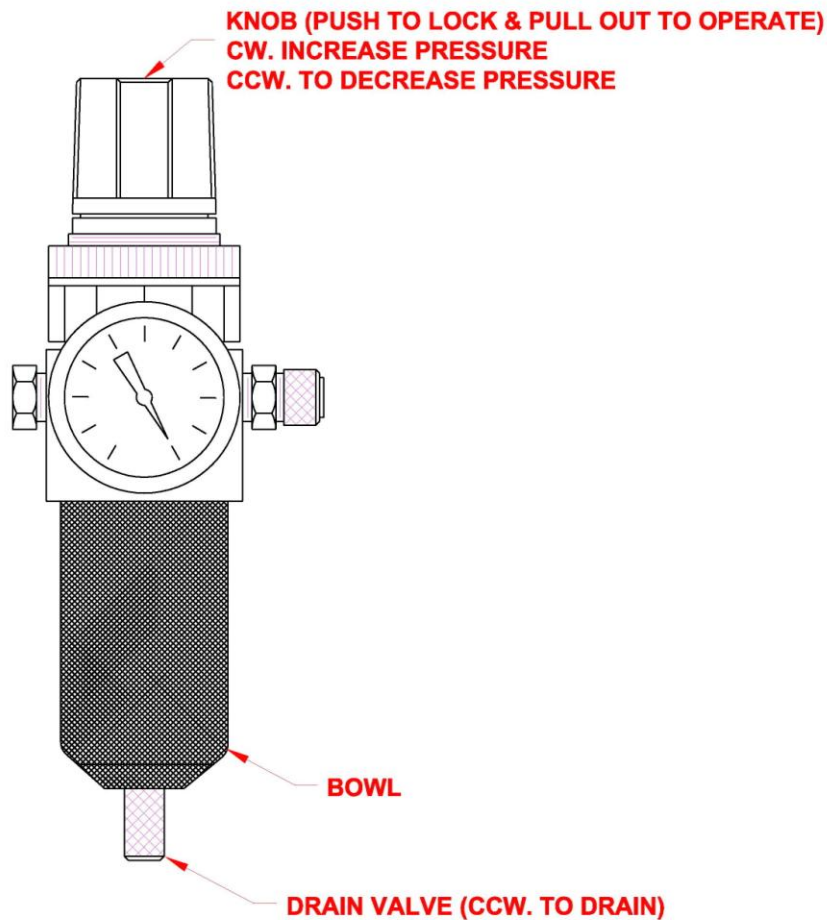

Fig. 13 Filter Regulator.

Maintenance

To obtain best efficiency and longer period of trouble-free operation, the air supply must be moisture free and clean, as dirt is the most common cause of erratic regulator operation. If using in-house air supply, it is recommended that the user maintain the air supplied to the system dirt-free by using another regulator with 20 micron filter between the air-supply and the system filter-regulator. Provisions for this are to be made by the customer. To clean, it is not necessary to remove unit from its piping or line. At the bottom of the bowl is a drain valve (see Fig 6) which should be periodically opened, (turn clockwise) particularly when sediments or moisture collect in the bowl.

APPENDIX

WARRANTY

Equipment manufactured by Kinetic Systems, Inc. (KSI) is warranted against defective workmanship and materials for one (1) year from date of delivery. Defective material or items will be replaced at no charge. This warranty does not include labor to remove and install the material or item in question. Material returned under Warranty will not be accepted without the prior approval and assignment of a Return Authorization Number by KSI. All returns must be shipped Freight Prepaid unless KSI authorizes otherwise. In those instances where returns must be by Motor Freight (truck), KSI will furnish the proper commodity rate classification for lowest shipping cost.